

MKBL121000 12V 100Ah



The KAISE LONG LIFE Series 10 years has been designed for different applications, such as UPS, electric and telecommunications applications that require a long useful life.



Performance Characteristics

Nominal Voltage	12V	
Dimensions	Length (mm / inch)	330 / 12.99
	Width (mm / inch)	171 / 6.73
	Height (mm / inch)	215 / 8.46
	Total Height (mm / inch)	222 / 8.74
Approx. Weight	(Kg / lbs) 29 / 63.9	
Design Life	10 years	
Terminal	M8	
Container Material	ABS	
Rated Capacity	104 Ah / 10.4A	(10hr, 1.70V / cell, 25°C / 77°F)
	85 Ah / 17.0A	(5hr, 1.70V / cell, 25°C / 77°F)
	59.7 Ah / 59.7A	(1hr, 1.70V / cell, 25°C / 77°F)
Max. Discharge Current	900A (5s)	
Internal Resistance	Approx 5.2 mΩ	
Operating Temp. Range	Discharge : -20 ~ 60°C (-4 ~ 140°F)	
	Charge : -10 ~ 60°C (14 ~ 140°F)	
	Storage : -20 ~ 60°C (-4 ~ 140°F)	
Nominal Operating Temp. Range	25 ± 3°C (77 ± 5°F)	
Cycle Use	Initial Charging Current less than 20A.	
	Voltage: 2.30VPC ~ 2.35VPC at 25°C (77°F)	
	Temp. Coefficient: -30mV/°C	
Standby Use	Initial Charging Current less than 20A.	
	2.25VPC~2.30VPC at 25° C (77°F)	
	Temp. Coefficient: -20mV/°C	
Capacity affected by	40°C (104°F)	103%
	25°C (77°F)	100%
	0°C (32°F)	86%
Self Discharge	Fully charged Kaise Long Life Series batteries may be stored for up to 6 months at 25°C (77°F) and then a freshening charge is required. For higher temperatures the time interval will be shorter.	

Constant Current Discharge (Amperes) at 77°F (25°C)

Volts/cell	15min	30min	1h	3h	5h	10h	20h
1.80V	136	87.4	57.1	22.8	16.3	10.0	5.30
1.75V	145	89.3	58.9	23.5	16.6	10.2	5.35
1.70V	156	92.2	59.7	24.1	17.0	10.4	5.40
1.65V	164	95.0	60.6	24.6	17.3	10.6	5.45
1.60V	173	98.9	61.0	25.1	17.6	10.8	5.50

Dimensions and Terminal (Unit: mm (inches))

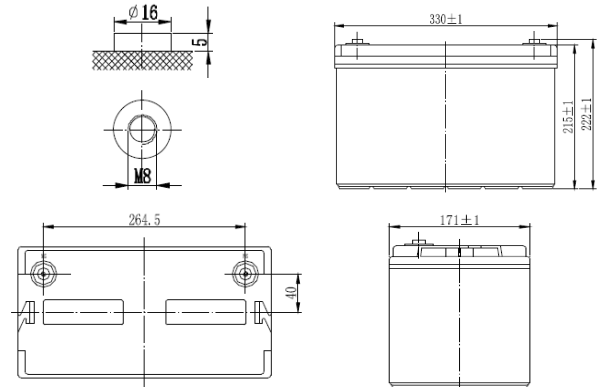

Applications

- UPS
- Telecommunications equipment
- Solar energy systems
- Cable TV
- Power station
- Marine equipment
- Military equipment
- Emergency power systems
- Railway systems

Certifications

ISO 9001:2008 ISO 14001:2008



Discharge Current vs. Discharge Voltage

Final discharge voltage V/CELL	1.8	1.75	1.7	1.6
Discharge current (A)	$I \leq 0.1CA$	$0.25CA \geq I > 0.1CA$	$0.55CA \geq I > 0.25CA$	$I > 0.55CA$

Constant Power Discharge (Watts per cell) at 77°F (25°C)

Volts/cell	15min	30min	1h	3h	5h
1.80V	270	164	109	45.9	32.9
1.75V	279	170	112	46.7	33.2
1.70V	290	176	116	47.3	33.3
1.65V	299	180	117	47.8	33.6
1.60V	304	186	119	48.4	33.8

(Note) The above characteristics data are average values obtained within three charge/discharge cycles not the minimum values.

Charging Characteristics (float use)

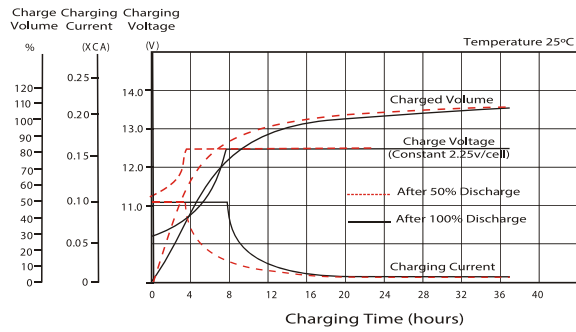

Cycle Life in Relation to Depth of Discharge

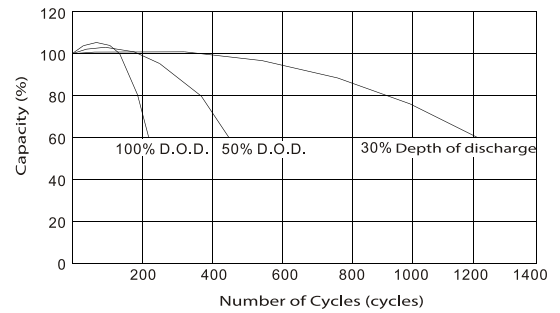

Temperature Effects in Relation to Battery Capacity

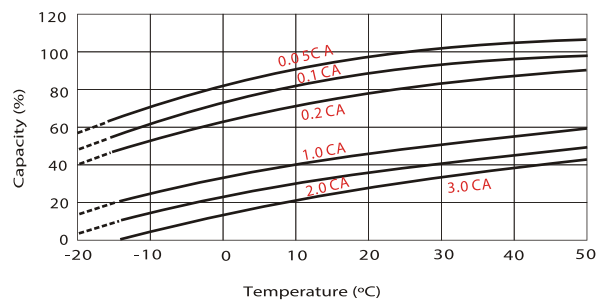

Effect of Temperature on Long Term Float Life

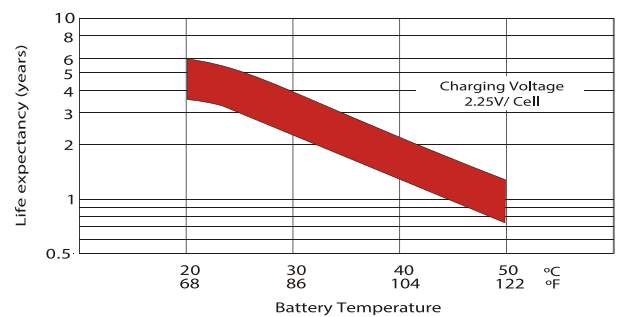

Self Discharge Characteristics

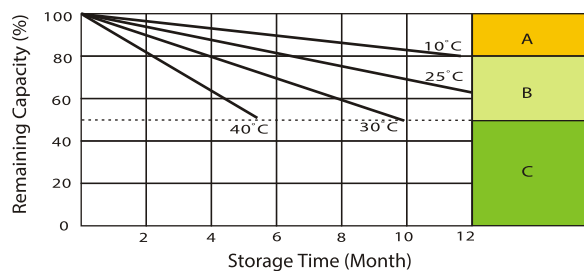

- A** No supplementary charge required (carry out supplementary charge before use if 100% capacity is required)
- B** Supplementary charge required before use. Optional charging way as below:
 1. Charged for above 3 days at limited current 0.25 CA and constant voltage 2.25V / cell.
 2. Charged for above 20 hours limited current 0.25CA and constant voltage 2.45V / cell.
 3. Charged for 8-10 hours at limited current 0.05 CA.
- C** Supplementary charge often fail to recover the capacity. The battery should never be left standing till this is reached.

IMPORTANT NOTE: The specifications presented herein are subject to revision without notice.

