

Hybrid Solar Inverter

Model	HIBS 3.5KW	HIBS 5.5KW
Rated Power	3500VA/3500W	5500VA/5500W
<b>Input</b>		
Voltage	230VAC	
Selectable Voltage Range	170~280VAC(For Personal Computers) 90~280VAC(For Home Appliances)	
Frequency Range	50Hz/60Hz(Auto sensing)	
<b>Output</b>		
AC Voltage Regulation(Batt.Mode)	230VAC±5%	
Surge Power	7000VA	11000VA
Efficienc(Peak)PV to INV	97%	
Efficienc(Peak)Battery to INV	94%	
Transfer Time	10ms(For Pensonal Computers);20ms(For Home Appliances)	
<b>Battery &amp; AC Charger</b>		
Battery Voltage	24VDC	48VDC
Floating Charge Voltage	27VDC	54VDC
Overcharge Protection	33VDC	63VDC
Maximum Charge Current	80A	80A
<b>Solar Charger</b>		
Maximum PV Array Power	5000W	6000W
MPPT Range @ Operating Voltage	120~450VDC	
Maximum PV Array Open Circuit Voltage	500VDC	
Maximum Charging Current	100A	100A
Maximum Efficiency	98%	
<b>Physical</b>		
Dimension,D*W*H(mm)	100*300*440	
Net Weight(kgs)	11	12
Communication Interface	USB/RS232/GPRS/WIFI	
<b>Operating Environment</b>		
Mumidity	5% to 95% Relative Humidity(Non~condensing)	
Operating Temperature	0°C~55°C	
Storage Temperature	-15°C~60°C	



# MKBL121000 12V 100Ah



The KAISE LONG LIFE Series 10 years has been designed for different applications, such as UPS, electric and telecommunications applications that require a long useful life.



## Performance Characteristics

Nominal Voltage	12V	
Dimensions	Length (mm / inch)	330 / 12.99
	Width (mm / inch)	171 / 6.73
	Height (mm / inch)	215 / 8.46
	Total Height (mm / inch)	222 / 8.74
Approx. Weight	(Kg / lbs) 29 / 63.9	
Design Life	10 years	
Terminal	M8	
Container Material	ABS	
Rated Capacity	104 Ah / 10.4A	(10hr, 1.70V / cell, 25°C / 77°F)
	85 Ah / 17.0A	(5hr, 1.70V / cell, 25°C / 77°F)
	59.7 Ah / 59.7A	(1hr, 1.70V / cell, 25°C / 77°F)
Max. Discharge Current	900A (5s)	
Internal Resistance	Approx 5.2 mΩ	
Operating Temp. Range	Discharge : -20 ~ 60°C (-4 ~ 140°F)	
	Charge : -10 ~ 60°C (14 ~ 140°F)	
	Storage : -20 ~ 60°C (-4 ~ 140°F)	
Nominal Operating Temp. Range	25 ± 3°C (77 ± 5°F)	
Cycle Use	Initial Charging Current less than 20A.	
	Voltage: 2.30VPC ~ 2.35VPC at 25°C (77°F)	
	Temp. Coefficient: -30mV/°C	
Standby Use	Initial Charging Current less than 20A.	
	2.25VPC~2.30VPC at 25° C (77°F)	
	Temp. Coefficient: -20mV/°C	
Capacity affected by	40°C (104°F)	103%
	25°C (77°F)	100%
	0°C (32°F)	86%
Self Discharge	Fully charged Kaise Long Life Series batteries may be stored for up to 6 months at 25°C (77°F) and then a freshening charge is required. For higher temperatures the time interval will be shorter.	

## Constant Current Discharge (Amperes) at 77°F (25°C)

Volts/cell	15min	30min	1h	3h	5h	10h	20h
1.80V	136	87.4	57.1	22.8	16.3	10.0	5.30
1.75V	145	89.3	58.9	23.5	16.6	10.2	5.35
1.70V	156	92.2	59.7	24.1	17.0	10.4	5.40
1.65V	164	95.0	60.6	24.6	17.3	10.6	5.45
1.60V	173	98.9	61.0	25.1	17.6	10.8	5.50

## Dimensions and Terminal (Unit: mm (inches))

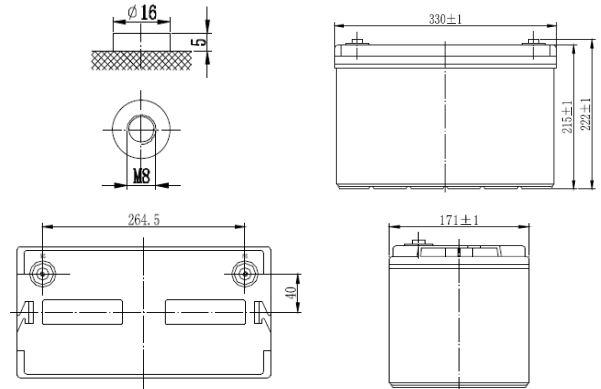

## Applications

UPS  
Telecommunications equipment  
Solar energy systems  
Cable TV  
Power station  
Marine equipment  
Military equipment  
Emergency power systems  
Railway systems

## Certifications

ISO 9001:2008 ISO 14001:2008



## Discharge Current vs. Discharge Voltage

Final discharge voltage V/CELL	1.8	1.75	1.7	1.6
Discharge current (A)	I ≤ 0.1CA	0.25CA ≥ I > 0.1CA	0.55CA ≥ I > 0.25CA	I > 0.55CA

## Constant Power Discharge (Watts per cell) at 77°F (25°C)

Volts/cell	15min	30min	1h	3h	5h
1.80V	270	164	109	45.9	32.9
1.75V	279	170	112	46.7	33.2
1.70V	290	176	116	47.3	33.3
1.65V	299	180	117	47.8	33.6
1.60V	304	186	119	48.4	33.8

(Note) The above characteristics data are average values obtained within three charge/discharge cycles not the minimum values.

## Charging Characteristics (float use)

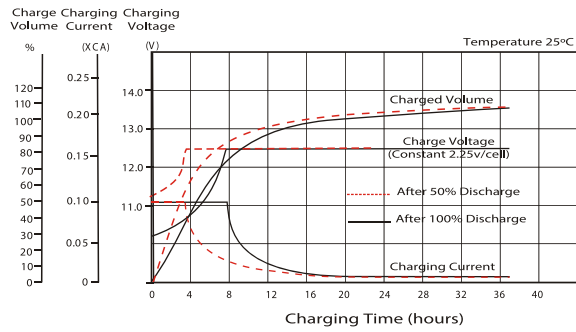

## Cycle Life in Relation to Depth of Discharge

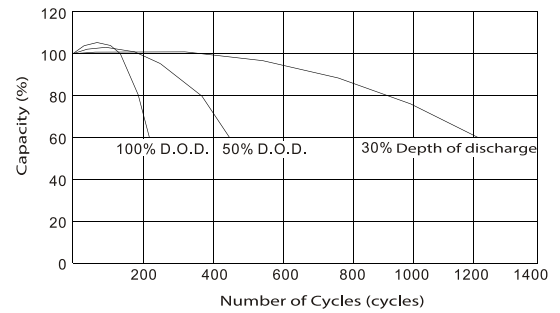

## Temperature Effects in Relation to Battery Capacity

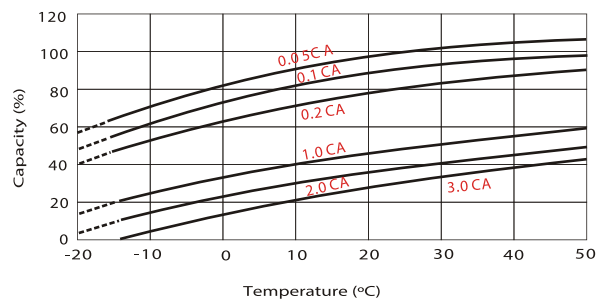

## Effect of Temperature on Long Term Float Life

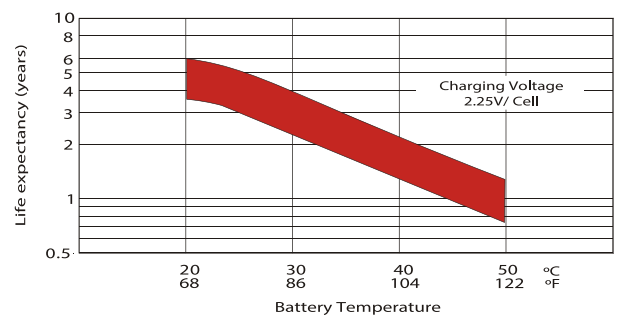

## Self Discharge Characteristics

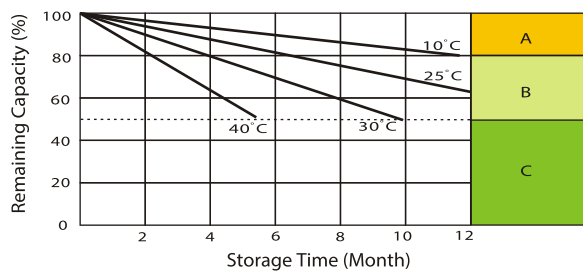

- A** No supplementary charge required (carry out supplementary charge before use if 100% capacity is required)
- B** Supplementary charge required before use. Optional charging way a below:
  1. Charged for above 3 days at limited current 0.25 CA and constant voltage 2.25V / cell.
  2. Charged for above 20 hours limited current 0.25CA and constant voltage 2.45V / cell.
  3. Charged for 8-10 hours at limited current 0.05 CA.
- C** Supplementary charge often fail to recover the capacity. The battery should never be left standing till this is reached.

IMPORTANT NOTE: The specifications presented herein are subject to revision without notice.

# HiPower Series

144-CELL HALF CUT MONOCRYSTALLINE  
SOLAR MODULE

# 450 Watt

STPXXXS - B72H/Vnh



## Features



**High power output**  
Compared to 158.75mm module, the power output can increase 25W-30W



**Suntech current sorting process**  
System output maximized by reducing mismatch losses up to 2% with modules sorted & packaged by amperage



**Excellent weak light performance**  
More power output in weak light condition, such as haze, cloudy, and morning



**Lower operating temperature**  
Lower operating temperature and temperature coefficient increases the power output



**Extended load tests**  
Module certified to withstand front side maximum static test load (5400 Pascal) and rear side maximum static test loads (3800 Pascal) \*



**Withstanding harsh environment**  
Reliable quality leads to a better sustainability even in harsh environment like desert, farm and coastline

Certifications and standards:  
IEC 61215, IEC 61730, conformity to CE



## Trust Suntech to Deliver Reliable Performance Over Time

- World-class manufacturer of crystalline silicon photovoltaic modules
- Unrivaled manufacturing capacity and world-class technology
- Rigorous quality control meeting the highest international standards: ISO 9001, ISO 14001 and ISO17025
- Regular independently checked production process from international accredited institute/company
- Long-term reliability tests
- 2 × 100% EL inspection ensuring defect-free modules

## Special Cell Design



The unique cell design leads to reduced electrodes resistance and smaller current, thus enables higher fill factor. Meanwhile, it can reduce losses of mismatch and cell wear, and increase total reflection.

## Industry-leading Warranty based on nominal power

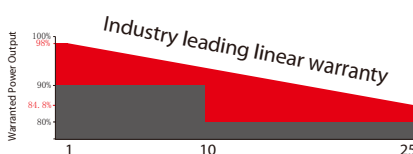

- 98% in the first year, thereafter, for years two (2) through twenty-five (25), 0.55% maximum decrease from MODULE's nominal power output per year, ending with the 84.8% in the 25th year after the defined WARRANTY STARTING DATE.\*\*\*\*
- 15-year product warranty
- 25-year linear performance warranty

## IP68 Rated Junction Box



The Suntech IP68 rated junction box ensures an outstanding waterproof level, supports installations in all orientations and reduces stress on the cables. High reliable performance, low resistance connectors ensure maximum output for the highest energy production.

\* Please refer to Suntech Standard Module Installation Manual for details. \*\*WEEE only for EU market.  
\*\*\* Please refer to Suntech Product Warranty for details.  
made in China & Vietnam

### Electrical Characteristics

STC	STPXXS-B72H/Vnh				
Maximum Power at STC (Pmax)	450 W	445 W	440 W	435 W	430 W
Optimum Operating Voltage (Vmp)	41.4 V	41.2 V	41.0 V	40.8 V	40.6 V
Optimum Operating Current (Imp)	10.87 A	10.81 A	10.74 A	10.67 A	10.60 A
Open Circuit Voltage (Voc)	49.2 V	49.0 V	48.8 V	48.6 V	48.4 V
Short Circuit Current (Isc)	11.61 A	11.54 A	11.47 A	11.40 A	11.32 A
Module Efficiency	20.7%	20.4%	20.2%	20.0%	19.8%
Operating Module Temperature	-40 °C to +85 °C				
Maximum System Voltage	1500 V DC (IEC)				
Maximum Series Fuse Rating	20 A				
Power Tolerance	0/+5 W				

STC: Irradiance 1000 W/m<sup>2</sup>, module temperature 25 °C, AM=1.5;  
Tolerance of Pmax is within +/- 5% and tolerances of Voc and Isc are within +/- 5%.

NMOT	STPXXS-B72H/Vnh				
Maximum Power at NMOT (Pmax)	339.4 W	335.8 W	332.7 W	327.7 W	324.6 W
Optimum Operating Voltage (Vmp)	38.2 V	38.0 V	37.8 V	37.6 V	37.5 V
Optimum Operating Current (Imp)	8.89 A	8.84 A	8.78 A	8.73 A	8.67 A
Open Circuit Voltage (Voc)	46.2 V	46.0 V	45.8 V	45.5 V	45.4 V
Short Circuit Current (Isc)	9.37 A	9.31 A	9.25 A	9.20 A	9.13 A

NMOT: Irradiance 800 W/m<sup>2</sup>, ambient temperature 20 °C, AM=1.5, wind speed 1 m/s.

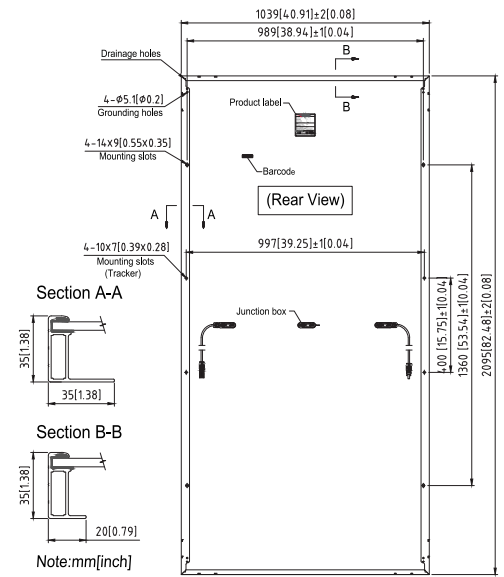

### Temperature Characteristics

Nominal Module Operating Temperature (NMOT)	42 ± 2 °C
Temperature Coefficient of Pmax	-0.36%/°C
Temperature Coefficient of Voc	-0.304%/°C
Temperature Coefficient of Isc	0.050%/°C

### Mechanical Characteristics

Solar Cell	Monocrystalline silicon 166 mm
No. of Cells	144 (6 × 24)
Dimensions	2095 × 1039 × 35 mm (82.5 × 40.9 × 1.4 inches)
Weight	24.5 kgs (54.0 lbs.)
Front Glass	3.2 mm (0.13 inches) tempered glass
Frame	Anodized aluminium alloy
Junction Box	IP68 rated (3 bypass diodes)
Output Cables	4.0 mm <sup>2</sup> , Portrait: (-)350 mm and (+)160 mm in length Landscape: (-)1400 mm and (+)1400 mm in length or customized length
Connectors	Genuine MC4 EVO2, TL-Cable01S
Fire Class Rating	C in accordance with UL 790

### Packing Configuration

Container	20' GP	40' HC
Pieces per pallet	31	31
Pallets per container	5	22
Pieces per container	155	682
Packaging box dimensions	2125×1130×1205 mm	
Packaging box weight	812 kg	

Information on how to install and operate this product is available in the installation instruction. All values indicated in this data sheet are subject to change without prior announcement. The specifications may vary slightly. All specifications are in accordance with standard EN 50380. Color differences of the modules relative to the figures as well as discolorations of/in the modules which do not impair their proper functioning are possible and do not constitute a deviation from the specification.

### Current-Voltage & Power-Voltage Curve (450S)

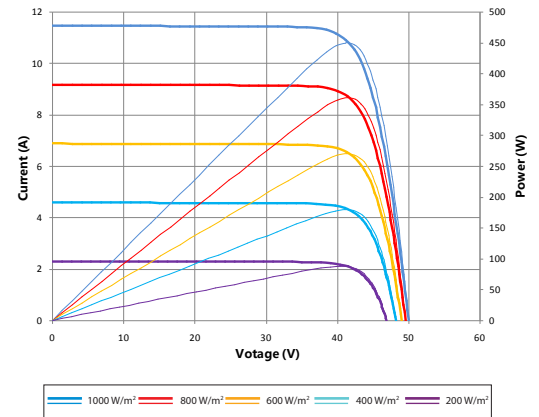

### Dealer information

