

Product Overview

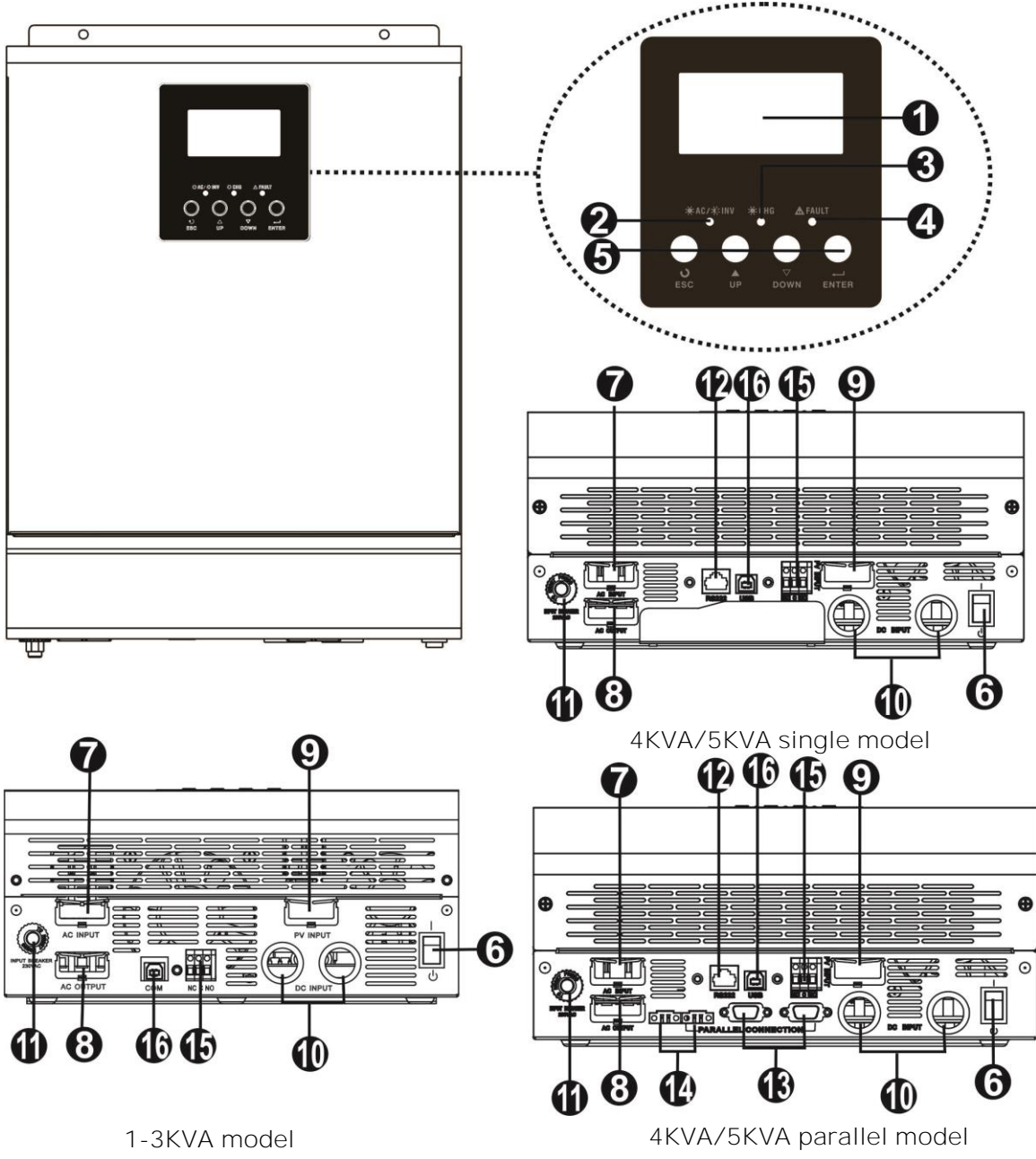

1-3KVA model

4KVA/5KVA single model

4KVA/5KVA parallel model

NOTE: For parallel model installation and operation, please check separate parallel installation guide for the details.

1. LCD display
2. Status indicator
3. Charging indicator
4. Fault indicator
5. Function buttons
6. Power on/off switch
7. AC input
8. AC output
9. PV input
10. Battery input
11. Circuit breaker
12. RS232 communication port
13. Parallel communication cable (only for parallel model)
14. Current sharing cable (only for parallel model)
15. Dry contact
16. USB communication port

PV Module Selection:

When selecting proper PV modules, please be sure to consider below parameters:

1. Open circuit Voltage (Voc) of PV modules not exceeds max. PV array open circuit voltage of inverter.
2. Open circuit Voltage (Voc) of PV modules should be higher than min. battery voltage.

Solar Charging Mode					
INVERTER MODEL	1KVA 12V	1KVA 24V 2KVA 24V 3KVA 24V	1KVA 48V 3KVA 48V	2KVA 24V Plus/ 3KVA 24V Plus	2KVA 48V Plus/ 3KVA 48V Plus/ 4KVA/5KVA
Max. PV Array Open Circuit Voltage	102Vdc max	75Vdc max	102Vdc max	145Vdc	
PV Array MPPT Voltage Range	15~80Vdc	30~66Vdc	60~88Vdc	30~115Vdc	60~115Vdc
Min. battery voltage for PV charge	8.5Vdc	17Vdc	34Vdc	17Vdc	34Vdc

Please follow below steps to implement PV module connection:

1. Remove insulation sleeve 10 mm for positive and negative conductors.
2. Check correct polarity of connection cable from PV modules and PV input connectors. Then, connect positive pole (+) of connection cable to positive pole (+) of PV input connector. Connect negative pole (-) of connection cable to negative pole (-) of PV input connector.

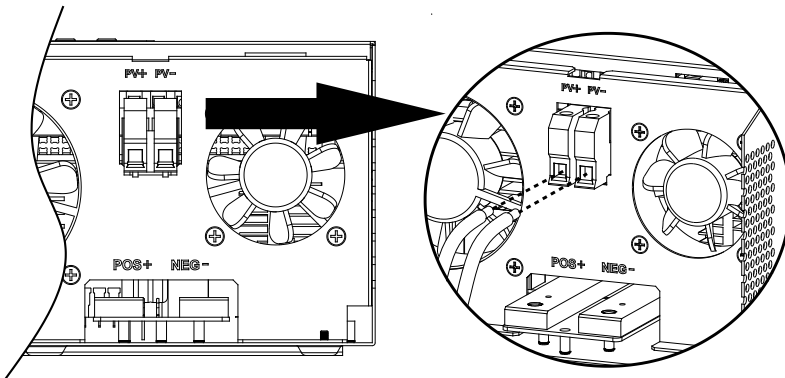
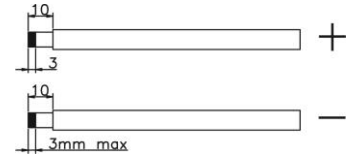

3. Make sure the wires are securely connected.

Final Assembly

After connecting all wirings, please put bottom cover back by screwing two screws as shown below.

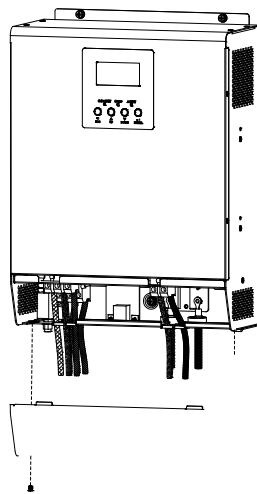

1KVA/2KVA/3KVA/4KVA/5KVA



2KVA /3KVA

SPECIFICATIONS

Table 1 Line Mode Specifications

INVERTER MODEL	1KVA 12V 1KVA 24V 2KVA 24V 3KVA 24V 1KVA 48V 3KVA 48V	2KVA 24V Plus 3KVA 24V Plus 2KVA 48V Plus 3KVA 48V Plus	4KVA 5KVA
Input Voltage Waveform	Sinusoidal (utility or generator)		
Nominal Input Voltage	230Vac		
Low Loss Voltage	170Vac± 7V (UPS) 90Vac± 7V (Appliances)		
Low Loss Return Voltage	180Vac± 7V (UPS); 100Vac± 7V (Appliances)		
High Loss Voltage	280Vac± 7V		
High Loss Return Voltage	270Vac± 7V		
Max AC Input Voltage	300Vac		
Nominal Input Frequency	50Hz / 60Hz (Auto detection)		
Low Loss Frequency	40± 1Hz		
Low Loss Return Frequency	42± 1Hz		
High Loss Frequency	65± 1Hz		
High Loss Return Frequency	63± 1Hz		
Output Short Circuit Protection	Line mode: Circuit Breaker Battery mode: Electronic Circuits		
Efficiency (Line Mode)	>95% (Rated R load, battery full charged)		
Transfer Time	10ms typical (UPS); 20ms typical (Appliances)		
Output power derating: When AC input voltage drops to 95V or 170V depending on models, the output power will be derated.			

Table 2 Inverter Mode Specifications

INVERTER MODEL	1KVA 12V	1KVA 24V 2KVA 24V 3KVA 24V 2KVA 24V Plus 3KVA 24V Plus	1KVA 48V 3KVA 48V 2KVA 48V Plus 3KVA 48V Plus	4KVA 5KVA
Rated Output Power	1KVA/1KW	1KVA/1KW 2KVA/2KW 3KVA/3KW	1KVA/1KW 2KVA/2KW 3KVA/3KW	4KVA/4KW 5KVA/5KW
Output Voltage Waveform	Pure Sine Wave			
Output Voltage Regulation	230Vac± 5%			
Output Frequency	60Hz or 50Hz			
Peak Efficiency	90%			
Overload Protection	5s@≥150% load ; 10s@110%~150% load			
Surge Capacity	2* rated power for 5 seconds			
Nominal DC Input Voltage	12Vdc	24Vdc	48Vdc	
Cold Start Voltage	11.5Vdc	23.0Vdc	46.0Vdc	
Low DC Warning Voltage @ load < 20%	11.0Vdc	22.0Vdc	44.0Vdc	
@ 20% ≤ load < 50%	10.7Vdc	21.4Vdc	42.8Vdc	
@ load ≥ 50%	10.1Vdc	20.2Vdc	40.4Vdc	
Low DC Warning Return Voltage @ load < 20%	11.5Vdc	23.0Vdc	46.0Vdc	
@ 20% ≤ load < 50%	11.2Vdc	22.4Vdc	44.8Vdc	
@ load ≥ 50%	10.6Vdc	21.2Vdc	42.4Vdc	
Low DC Cut-off Voltage @ load < 20%	10.5Vdc	21.0Vdc	42.0Vdc	
@ 20% ≤ load < 50%	10.2Vdc	20.4Vdc	40.8Vdc	
@ load ≥ 50%	9.6Vdc	19.2Vdc	38.4Vdc	
High DC Recovery Voltage	14.5Vdc	29Vdc	58Vdc	58Vdc or 62Vdc
High DC Cut-off Voltage	15.5Vdc	31Vdc	62Vdc	60Vdc or 66Vdc
No Load Power Consumption	<15W	<25W		<50W
Saving Mode Power Consumption	<5W	<10W		<15W

Table 3 Charge Mode Specifications

Utility Charging Mode						
INVERTER MODEL		1KVA 12V	1KVA 24V	2KVA 24V 3KVA 24V 2KVA 24V Plus 3KVA 24V Plus	1KVA 48V 3KVA 48V 2KVA 48V Plus 3KVA 48V Plus	4KVA 5KVA
Charging Current (UPS) @ Nominal Input Voltage		10/20A		20/30A	10/15A	2/10A/ 20/30A/ 40/50/60A
Bulk Charging Voltage	Flooded Battery	14.6	29.2		58.4	
	AGM / Gel Battery	14.1	28.2		56.4	
Floating Charging Voltage		13.5Vdc	27Vdc		54Vdc	54Vdc or 64Vdc
Overcharge Protection		15.5Vdc	31Vdc		60Vdc	66Vdc
Charging Algorithm		3-Step				
Charging Curve						

Solar Charging Mode						
INVERTER MODEL	1KVA 12V	1KVA 24V 2KVA 24V 3KVA 24V	1KVA 48V 3KVA 48V	2KVA 24V Plus 3KVA 24V Plus	2KVA 48V Plus 3KVA 48V Plus	4KVA 5KVA
Rated Power	500W	600W	900W	1500W	3000W	4000W
Efficiency	98.0% max.					
Max. PV Array Open Circuit Voltage	102Vdc	75Vdc	102Vdc	145Vdc		
PV Array MPPT Voltage Range	15~80Vdc	30~66Vdc	60~88Vdc	30~115Vdc	60~115Vdc	
Min battery voltage for PV charge	8.5Vdc	17Vdc	34Vdc	17Vdc	34Vdc	
Standby Power Consumption	2W					
Battery Voltage Accuracy	+/-0.3%					
PV Voltage Accuracy	+/-2V					
Charging Algorithm	3-Step					
Joint Utility and Solar Charging						
Max Charging Current	60Amp	1K: 45Amp 2K/3K: 55Amp	33Amp	90Amp	75Amp	140Amp
Default Charging Current	40Amp	1K: 20Amp 2K/3K: 30Amp	20Amp	60 Amp	60 Amp	60Amp

Table 4 General Specifications

INVERTER MODEL	1KVA 12V 1KVA 24V 1KVA 48V	2KVA 24V	3KVA 24V 3KVA 48V	2KVA 24V Plus 3KVA 24V Plus 2KVA 48V Plus 3KVA 48V Plus	4KVA	5KVA
Safety Certification	CE					
Operating Temperature Range	0°C to 55°C					
Storage temperature	-15°C~ 60°C					
Humidity	5% to 95% Relative Humidity (Non-condensing)					
Dimension (D*W*H), mm	100 x 272 x 355			140 x 295 x 479	120 x 295 x 468	
Net Weight, kg	6.8	7.0	7.4	11.5	11	



PHONO



575-595w

Draco Module Series

N-TOPCON HIGH EFFICIENCY 144-16BB-W-WG

Bloomberg
NEW ENERGY FINANCE

Tier1



Extraordinary Product Performance

- Up to 30% additional power yield benefited from bifacial technology and up over 80% cell bifaciality
- Competitive high-temperature performance with ameliorated temperature coefficient
- Better weak illumination response, higher power generation with N-TOPCon technology

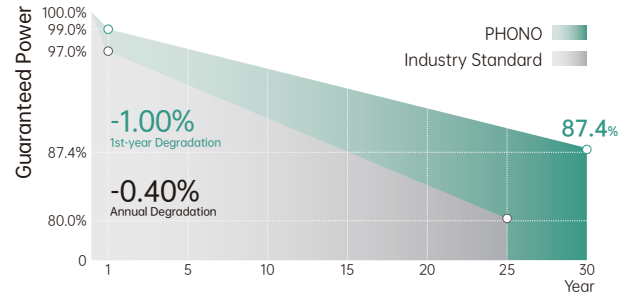

15-year
Product Warranty

30-year
Linear Performance Warranty

Higher Quality Reliability

- N-type with lower LID and LeTID
- Industry-leading cell processing technology and dual glass contributes to excellent anti-PID characteristic
- First-year degradation is less than 1.0%, with linear degradation of 0.4% per year for 30 years

MANAGEMENT SYSTEM CERTIFICATES

IEC 61215, IEC 61730

ISO 9001
2015 / Quality management system

ISO 14001
2015 / Standards for environmental management system

ISO 45001
2018 / International standards for occupational health & safety

Wider Application Conditions

- BIPV, vertical installation, snowfield, high-humid area, windy and dusty area
- Safer and easier handling during transportation and installation



Electrical Typical Values

Model	1000V	PS575M8GF-24/TNH		PS580M8GF-24/TNH		PS585M8GF-24/TNH		PS590M8GF-24/TNH		PS595M8GF-24/TNH	
	1500V	PS575M8GFH-24/TNH		PS580M8GFH-24/TNH		PS585M8GFH-24/TNH		PS590M8GFH-24/TNH		PS595M8GFH-24/TNH	
Testing Condition		STC	NOCT	STC	NOCT	STC	NOCT	STC	NOCT	STC	NOCT
Rated Power (Pmpp)		575	440	580	444	585	448	590	452	595	456
Rated Current (Imp)		13.36	10.76	13.42	10.81	13.48	10.86	13.54	10.91	13.60	10.95
Rated Voltage (Vmp)		43.04	40.92	43.22	41.09	43.40	41.26	43.58	41.43	43.75	41.59
Short Circuit Current (Isc)		14.04	11.31	14.11	11.36	14.18	11.42	14.25	11.48	14.32	11.53
Open Circuit Voltage (Voc)		51.97	49.76	52.20	49.98	52.44	50.21	52.68	50.44	52.92	50.67
Module Efficiency (%)		22.26		22.45		22.65		22.84		23.03	

STC(Standard Testing Conditions): Irradiance 1000W/m², AM 1.5, Cell Temperature 25°C

NOCT (Nominal Operation Cell Temperature): Irradiance 800W/m², Ambient Temperature 20°C , Spectra at AM1.5, Wind at 1m/s

BNPI

Maximum Power (Pmax)	633	639	644	650	655
Optimum Operating Current (Imp)	14.71	14.97	14.84	14.92	14.98
Optimum Operating Voltage (Vmp)	43.04	43.22	43.40	43.58	43.75
Short Circuit Current (Isc)	15.49	15.58	15.62	15.70	15.75
Open Circuit Voltage (Voc)	51.97	52.20	52.44	52.68	52.92

BNPI:Front Side Irradiation 1000W/m², Back Side Reflection Irradiation 135W/m², AM 1.5, Ambient Temperature 25°C

Mechanical Characteristics

Cell Type	N Type Monocrystalline
Dimension (L × W × H)	Length: 2278mm (89.69 inch)
	Width: 1134mm (44.65 inch)
	Height: 30mm (1.18 inch)
Weight	32.0kg (70.55 lbs)
Glass	2.0mm/2.0mm Heat Strengthened Glass
Frame	Anodized Aluminium Alloy
Cable (Including Connector)	4mm ² (IEC), (+): 350mm,(-): 250mm or Customized Length
Junction Box	IP 68 Rated

Temperature Ratings

Voltage Temperature Coefficient	-0.25%/°C
Current Temperature Coefficient	+0.04%/°C
Power Temperature Coefficient	-0.29%/°C
Power Tolerance	0~+3%
NOCT	42±2°C
Bifaciality	80±5%

Absolute Maximum Rating

Operating Temperature	From -40 to + 85°C
Hail Diameter @ 80km/h	Up to 25mm
Front Side Maximum Static Loading	5400Pa
Rear Side Maximum Static Loading	2400Pa
Maximum Series Fuse Rating	30A
PV Module Classification	II
Fire Rating (IEC61730)	C
Maximum System Voltage	DC 1000V/1500V

Packing Configuration

Container	20' GP	40' HQ
Pieces/Container	180	720
Pcs/Pallet	36	36
Pallets/Container	5	20

Electrical Characteristics

