

# MKB2300 2V 300Ah



The Kaise Ultra Long Life series of VRLA batteries is known for having the most reliable and highest quality of the entire industry. Built with AGM technology, these batteries reach a service life of 20 years.



## Performance Characteristics

Nominal Voltage	2V	
Dimensions	Length (mm / inch)	170 / 6.69
	Width (mm / inch)	150 / 5.91
	Height (mm / inch)	330 / 12.99
	Total Height (mm / inch)	350 / 13.78
Approx. Weight	(Kg / lbs) 18.8 / 41.5	
Design Life	8 - 12 years	
Terminal	M8	
Container Material	ABS	
Rated Capacity	320.0Ah / 16.0 A	(20hr, 1.80V/cell, 25°C / 77°F)
	304.0Ah / 30.4 A	(10hr, 1.75V/cell, 25°C / 77°F)
	266.0Ah / 53.2 A	(5hr, 1.75V/cell, 25°C / 77°F)
	231.6Ah / 77.2 A	(3hr, 1.75V/cell, 25°C / 77°F)
	175.3Ah / 175.3 A	(1hr, 1.67V/cell, 25°C / 77°F)
Max. Discharge Current	2400A (5s)	
Internal Resistance	Approx 0.9mΩ	
Operating Temp. Range	Discharge : -20 ~ 55°C (-4 ~ 131°F)	
	Charge : 0 ~ 40°C (32 ~ 104°F)	
	Storage : -20 ~ 50°C (-4 ~ 122°F)	
Nominal Operating Temp. Range	25 ± 3°C (77 ± 5°F)	
Cycle Use	Initial Charging Current less than 60.0A	
	Voltage: 14.4V ~ 15.0V at 25°C (77°F)	
	Temp. Coefficient: -5mV/°C	
Standby Use	Initial Charging Current less than 60.0A	
	13.5V ~ 13.8V at 25°C (77°F)	
	Temp. Coefficient: -3mV/°C	
Capacity affected by Temperature	40°C (104°F)	103%
	25°C (77°F)	100%
	0°C (32°F)	86%
Self Discharge	Fully charged Kaise Solar Series batteries may be stored for up to 6 months at 25°C (77°F) and then a freshening charge is required. For higher temperatures the time interval will be shorter.	

## Constant Current Discharge (Amperes) at 77°F (25°C)

Volts/cell	20min	30min	45min	1h	5h	10h	20h
1.80V	302.7	241.5	189.9	157.4	51.7	30.0	16.0
1.75V	326.3	255.8	199.7	164.2	53.2	30.4	16.1
1.70V	349.1	268.4	207.2	169.9	54.2	30.8	16.3
1.67V	366.3	281.5	216.2	176.0	55.3	31.1	16.4
1.60V	379.8	291.2	222.0	180.2	56.1	31.6	16.5

## Dimensions and Terminal (Unit: mm (inches))

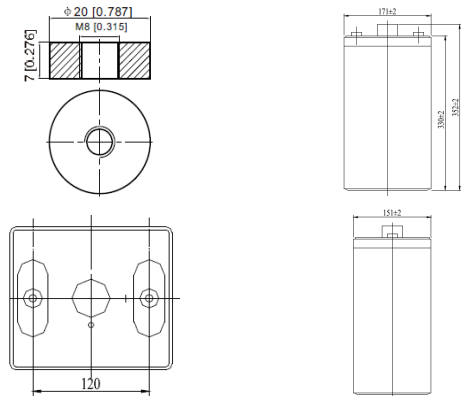

## Applications

- Renewable Energy
- Alarm systems
- Electric Test Equipment
- Emergency lighting systems
- Marine equipment
- Telecommunications systems

## Certifications

ISO 9001:2008 ISO 14001:2008



## Discharge Current vs. Discharge Voltage

Final discharge voltage V/CELL	1.8	1.75	1.7	1.6
Discharge current (A)	I ≤ 0.1CA	0.25CA ≥ I > 0.1CA	0.55CA ≥ I > 0.25CA	I > 0.55CA

## Constant Power Discharge (Watts per cell) at 77°F (25°C)

Volts/cell	15min	30min	45min	1h	5h	10h	20h
1.80V	569.7	457.9	362.7	302.7	101.3	59.6	31.8
1.75V	607.1	481.2	379.1	314.4	104.1	60.3	31.9
1.70V	644.0	500.7	390.7	323.7	105.6	61.0	32.3
1.67V	668.4	521.3	405.4	333.5	107.4	61.6	32.6
1.60V	685.1	533.7	412.4	338.9	108.6	62.4	32.7

(Note) The above characteristics data are average values obtained within three charge/discharge cycles not the minimum values.

## Charging Characteristic (cycle use)

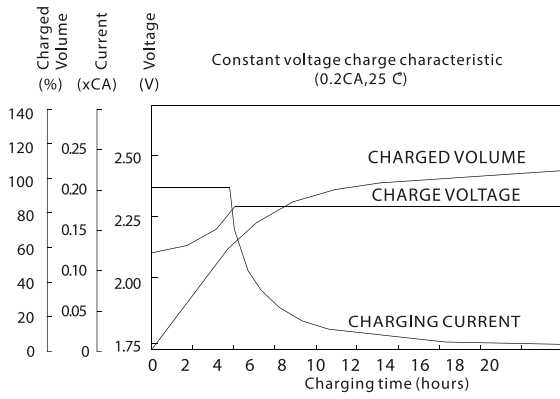

## Self Discharge Characteristics

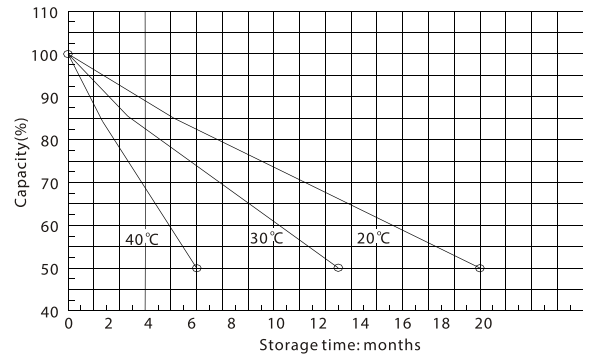

## Temperature Effects in Relation to Battery Capacity

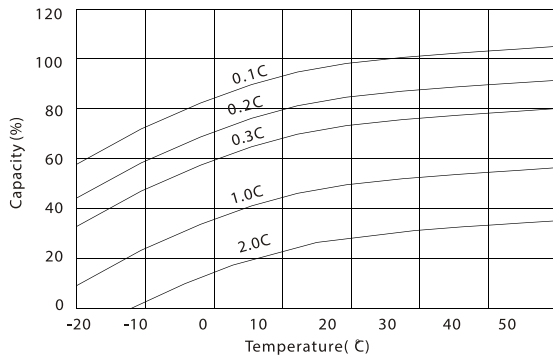

## Temperature Effects on Float Life

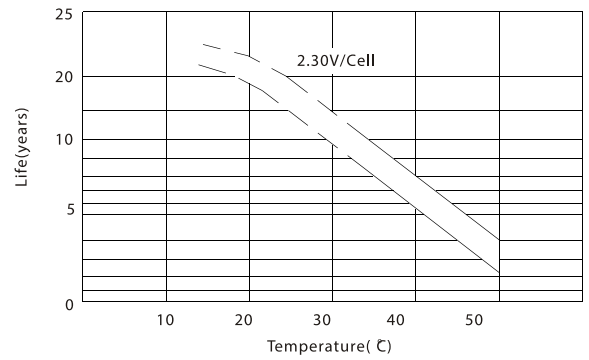

## Cycle Service Life in Relation to Depth of Discharge

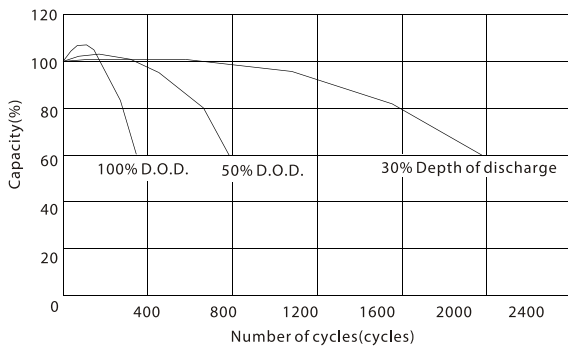

IMPORTANT NOTE: The specifications presented herein are subject to revision without notice.

